

Solo l'uso corretto delle istruzioni garantisce la sicurezza dell'apparecchio:
E' NECESSARIO CONSERVARLE
Disinserire la tensione prima di ogni intervento sull'apparecchio. Per un corretto montaggio vedere lo schema allegato.

This equipment is guaranteed only if used as indicated in these instructions:
PRESERVE THIS INSTRUCTIONS

Before any operation on this equipment, disconnect the power supply.
For a correct assembling see the here enclosed diagram.

La sécurité de l'appareil n'est garantie que par le respect des instructions suivantes.
IL EST NECESSAIRE LES CONSERVER
Disjoindre le courant de reseau avant tout operation sur l'appareil. Pour le montage suivre le schéma ici-joint.

Nur bei Befolgung der nachfolgenden Anweisungen, ist die Sicherheit des Gerats gewährleistet.
AUFBEWAHREN SIE BITTE DIE ANWEISUNGEN
Abschalten die Netzspannung vor Ausweshlisen der lampe. Fur eine einwaldfrei Montage siehe Beigefutges.

Solamente el correcto cumplimiento de las instrucciones puede garantizar la seguridad del aparato:
ES NECESARIO CUMPLIRLAS.
Desconectar la tensión antes de cualquiera intervención en el aparato. Para un ensamblaje correcto, consultar el esquema adjunto.

Rev 10-2021

LANCIA

design: P. Peperè

made in Italy

ART. 3522

H 180 cm
~ 50/60Hz 220-240V
/W - LED 31,5W 4000K CRI>90
/WW - LED 31,5W 3000K CRI>90
/XW - LED 31,5W 2700K CRI>90

ART. 3523

H 205 cm
~ 50/60Hz 220-240V
/W - LED 36W 4000K CRI>90
/WW - LED 36W 3000K CRI>90
/XW - LED 36W 2700K CRI>90

ART. 3524

H 180 cm
~ 50/60Hz 220-240V
/W - LED 52,5W 4000K CRI>90
/WW - LED 52,5W 3000K CRI>90
/XW - LED 52,5W 2700K CRI>90

ART. 3525

H 205 cm
~ 50/60Hz 220-240V
/W - LED 60W 4000K CRI>90
/WW - LED 60W 3000K CRI>90
/XW - LED 60W 2700K CRI>90

	<p>Questo prodotto non deve essere smaltito come rifiuto municipale misto, effettuare una raccolta separata. This product must not be discarded as the responsibility of the City sanitation department, it must be gathered together separatily and discarded. Ce produit ne doit pas etre mis avec les ordures municipales, il faut effectuer un ramassage séparé. Dieses Produkt darf nicht als Gemeindekehricht entsorgt werden. Entsorgung muss getrennt erfolgen. Este producto no puede ser desechado como basura municipal mixta, efectuar recogida selectiva.</p>
	<p>Apparecchio adatto ad essere installato su superfici normalmente infiammabili. Appareil pouvant être installé sur des surfaces normalement inflammables. Fixture ready for mouting on normally inflammable surfaces. Apparat, der auf normal entflammbare Oberflächen angebracht werden kann. Aparato idóneo para ser utilizado en superficies normalmente inflamables.</p>
	<p>Apparecchio in Classe II, munito di isolamento doppio o rinforzato. Fixture on Class II, with double or reinforced insulation. Appareil en Classe II, équipé double d'isolation. Gerät, Klasse II, mit doppelter oder verstärkter Isolierung.</p>



EGOLUCE s.r.l. - via I. Newton, 12 - 20016 Pero, Milano - Italy
Tel. +39 02339586.1 - Fax +39 023535112 - www.egoluce.com info@egoluce.com

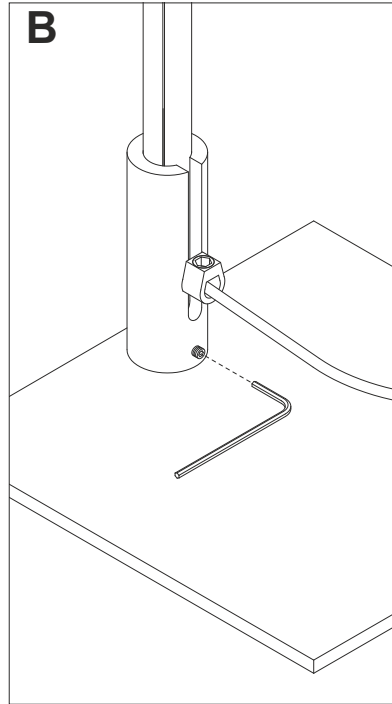
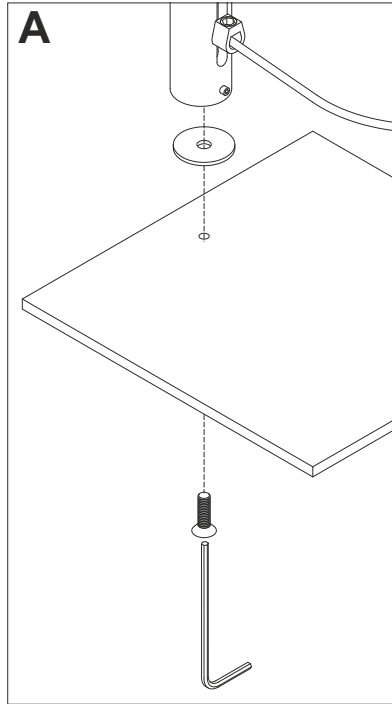

art. 3522 - 3523
 Regolazione a pedale
 con interruttore di fine corsa
*Pedal adjustment
 with end-of run switch*

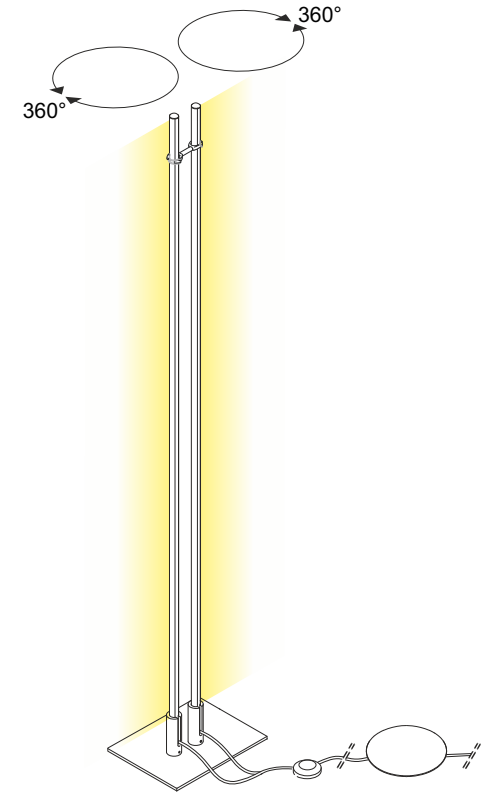
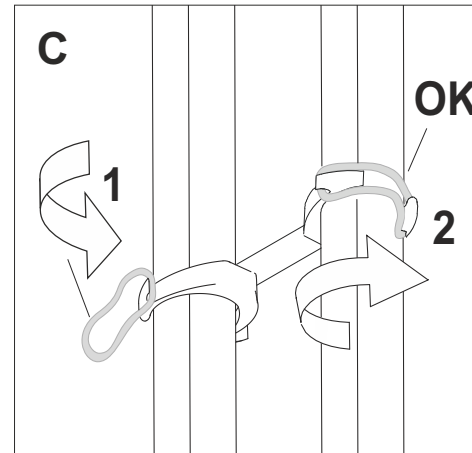
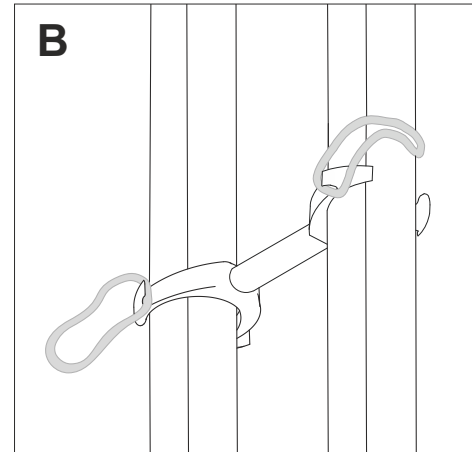
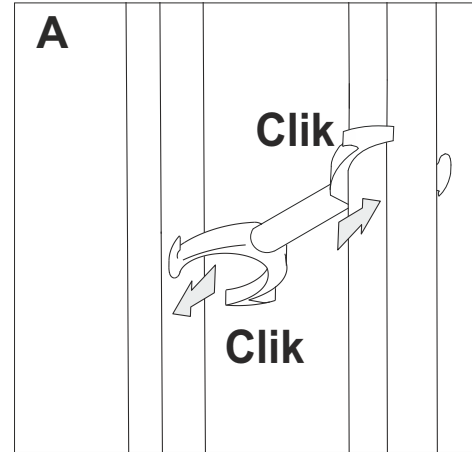
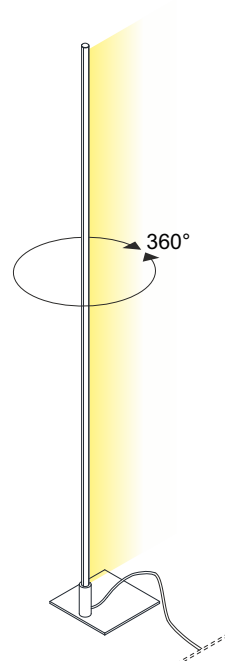

art. 3524 - 3525
 Regolazione a pressione
Pressure adjustment